

PRO-SERIES

Semi-Automatic Turntable Stretch Wrapper

ARPAC®

A DURAVANT COMPANY



High-Profile
Wrap-N-Weigh Option Shown

Low-Profile

FEATURES AND BENEFITS

Machine Features

- Heavy-duty, welded steel construction (no plastic panels) designed for long life
- Variable turntable speed using 1/2 hp, 90 Vdc motor with ANSI 50 chain drive system, no rubber belts
- Up to 12 RPM rotating table can deliver 25–40 loads per hour
- Long-range photo eye for automatic load height sensing
- Automatic top film over wrap control feature (TOC)
- Adjustable top and bottom illuminated LED wrap counters
- Cycle pause feature
- Electronic film tension adjustment control on control panel
- Manual jog control for turntable
- Eco-friendly, durable, powder coating

Film Delivery System

- EZ-Load® film pre-stretch dispenser for 20" film rolls
- Dual anti-static film rollers with manufacturer's lifetime warranty
- Film pre-stretch capability from 150 to 300% stretch (200% standard)
- Variable carriage speed up to 21 feet per minute
- 1/2 hp, 90 Vdc motor with ANSI 40 chain lift drive
- Dancer bar variable-corner compensation
- Electronic film tension adjustment control

Controls Hardware

- Allen-Bradley® power, control, and safety components
- Allen-Bradley® MicroLogix™ PLC
- UL/CSA approved components

OPTIONS

- Extended film towers for wrapping taller loads exceeding standard machine capability
- Top platen device to stabilize tall or light unstable loads during rotation
- Access ramps to assist loading of pallet
- Automatic film tear device (AFTD) tears film at the end of the wrapping cycle
- Split-frame construction to increase film tower clearance for oversized loads
- Cycle counter to count the actual cycles of machine operation
- Extended umbilical cords for split-frame models
- Integrated scale and printer available

Layout for Low Profile Shown

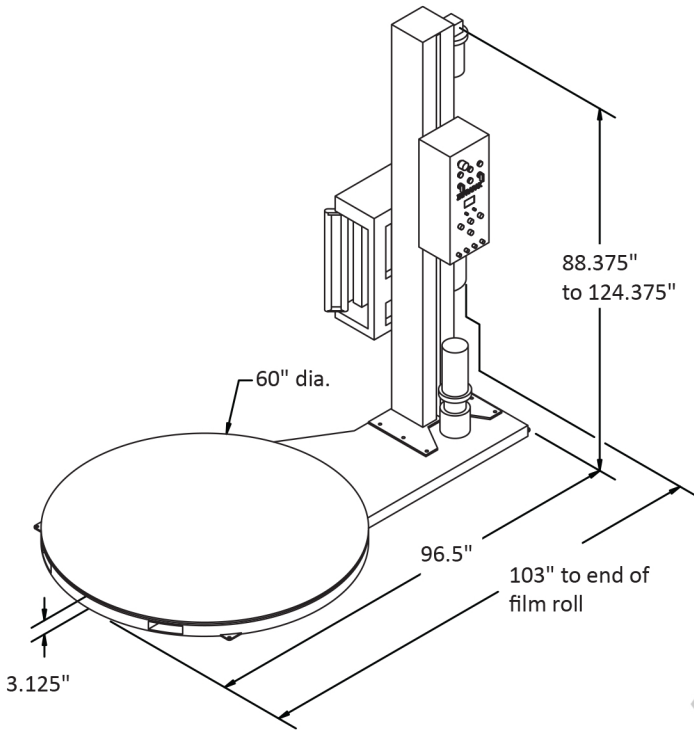

Specification	Measurement
Turntable size – low-profile	60" diameter (standard) 72" diameter (optional) (Larger sizes available)
Turntable size – high-profile	50" square (standard) 50 × 90" rectangular (option)
Max. load diagonal clearance	85" (standard turntable) 102" (optional turntable)
Max. load weight	4,000 lb. (standard)
Turntable rotation speed	Up to 12 RPM
Variable carriage speed	Up to 21 FPM
Loads wrapped per hour	25 to 40
Max. load height – low profile: - Standard Tower - Optional extensions available (12, 24, and 36")	81" max load height 93", 105", and 117" option
Max. load height – high profile: - Standard tower - Optional extensions available (12, 24, and 36")	74" max. load height 86", 98", and 110" option
Electrical power requirements	120 VAC, 1 Ph, 60 Hz, 10 A, 1.2 kW
Standard shipping weight	Low-profile 1,525 lb. High-profile 1,260 lb.



Wrap-N-Weigh Operator Display

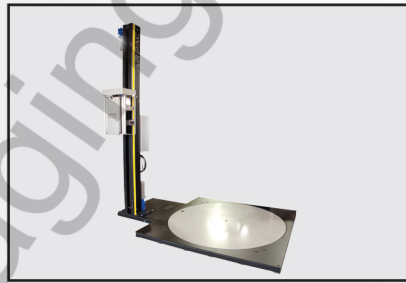

Optional Taller Tower and Larger Table Shown

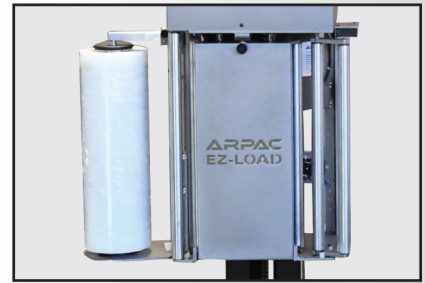

Easy Film Loading

JSSPackaging